

RUNI

RUNI WORM COMPACTOR

Suitable for almost all Types of Waste
and Packing Materials.

Minimizes Dust Pollution and solves Space Problems
through Volume Reduction.



RUNI WORM COMPACTOR

- a real innovative Solution!!



**PROYECTOS NAVALES
E INDUSTRIALES LIMITADA**
· ACUICULTURA, GAS - FILM ANTICORROSIVO
· PALAS - HORQUETAS PLASTICAS
· CARROS CRAEMER

FONO: (2) 777 7337
FAX: (2) 732 2382
E MAIL: pronaves@pronaves.cl
TENIENTE BISSON 821
INDEPENDENCIA
SANTIAGO - CHILE

RUNI WORM COMPACTOR

A simple but effective compaction of various waste materials.

RUNI



- ✓ Polystyrene
- ✓ Paper
- ✓ Plastics
- ✓ Sheet Metal
- ✓ Textile
- ✓ Rockwool,

Also separation of Liquids from:

- ✓ PET Bottles
- ✓ Waxed Cartons
- ✓ Filled Cans

THE HEART OF THE COMPACTOR



A solid worm compacts the material while being forced through RUNI's patented Adjustable Tube System.



For greasy and varying materials hydraulic jaws automatically control and secure the optimum density of the compacted material second by second.



For cleaned and homogeneous materials screw operated jaws can be adjusted manually eliminate are used.

INDIVIDUAL ADAPTION

THE WORM can be fed in many ways - depending on the type of waste materials.



Feed Hopper with Precrusher for bigger pieces of Polystyrene.



Situated under a rotary valve, cyclone or equipped conveyor.



Conveyors or roller drive for bigger pieces.



Feed Hopper adapted to an existing pipe conveyor

NOTE! All feed hoppers are equipped with a photoelectric cell for automatic start/stop of the worm.



**PROYECTOS NAVALES
E INDUSTRIALES LIMITADA**
- ACUICULTURA, GAS - FILM ANTICORROSIVO
- PALAS - HORQUETAS PLASTICAS
- CARROS CRAEMER

FONO: (2) 777 7337
FAX: (2) 732 2382
E MAIL: pronaves@pronaves.cl
TENIENTE BISSON 821
INDEPENDENCIA
SANTIAGO - CHILE

ADVANTAGES

- ✓ Saves storage space
- ✓ Semi or automatic operation
- ✓ Less containers
- ✓ Less collections
- ✓ Less transport cost
- ✓ Better working environment
 - Removes Dust Pollution
 - Reduces Bad Odors

The satisfaction of acting environmentally responsible.

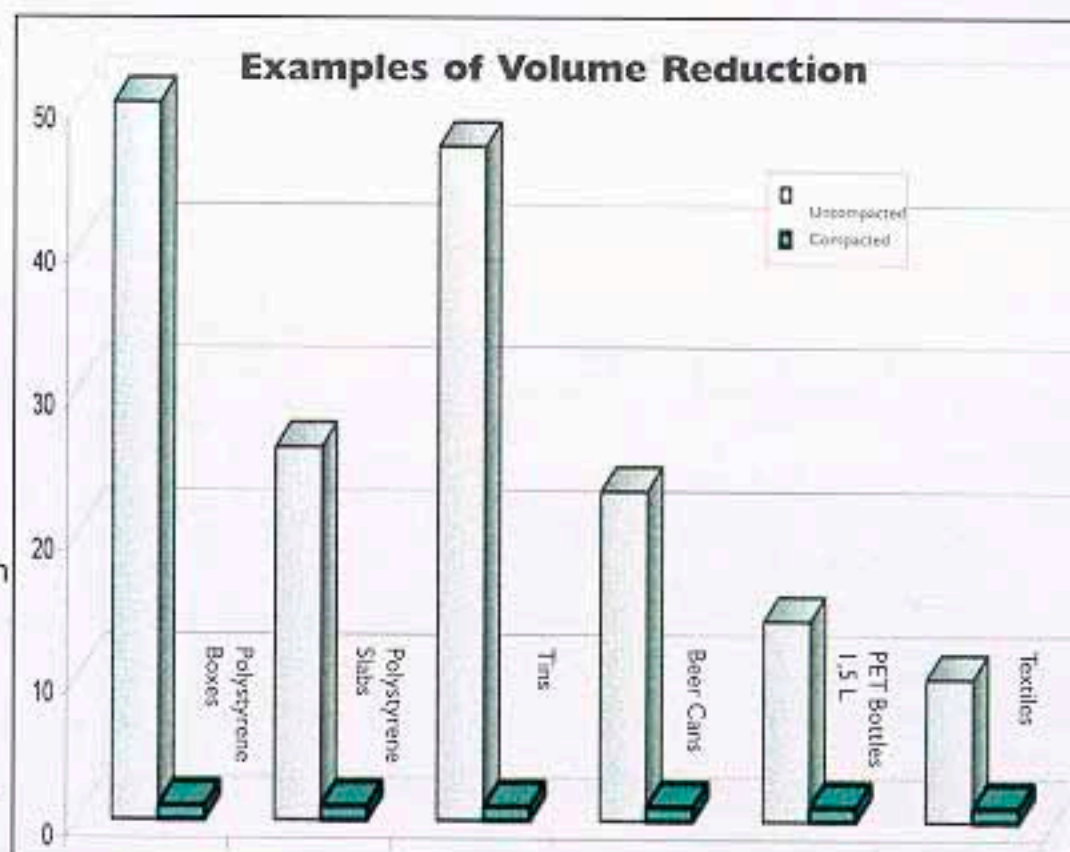

THE EASE OF OPERATION

- there are several possibilities of compacting.....



In open top containers or directly in closed container.



Compacted polystyrene is easily handled on pallets.
Weight: 300-400 kg/m³



Directly into an endless polystyrene tube to reduce dust emanation.

The decaying process of compacted wastes is slower and with less offensive odors.

OPERATOR SAFETY

1. CE standard.
2. Maintaining the necessary DB level of protection.
3. No loose cables or hoses.
4. The machine is shipped ready for operation on delivery. Excl. cable and plug.
5. Detailed Users Manual.



RUNI has over 25-years of experience with unequalled solutions for agriculture and processing industries.



**PROYECTOS NAVALES
E INDUSTRIALES LIMITADA**
· ACUICULTURA, GAS - FILM ANTICORROSIVO
· PALAS - HORQUETAS PLASTICAS
· CARROS CRAEMER

FONO: (2) 777 7337
FAX: (2) 732 2382
E MAIL: pronaves@pronaves.cl
TENIENTE BISSON 821
INDEPENDENCIA
SANTIAGO - CHILE

Technical Specifications

RUNI

SK 240 and SK 400 are available with both square and round discharge tubes.

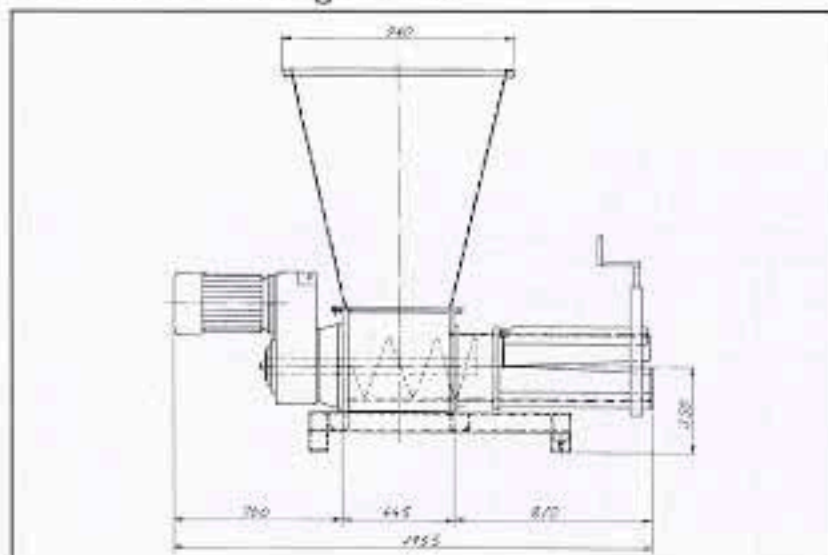

SK 240 with standard hopper and manually operated jaws

- ✓ Flatgear with 5,5 kW motor.
- ✓ Cabinet for automatic system.
- ✓ Photoelectric cell for automatic start / stop.
- ✓ Weight: approx. 600 kg.
- ✓ 3 x 380 V or 3 x 220 V, other voltages are available.
- ✓ Approx. 11 A at full load.

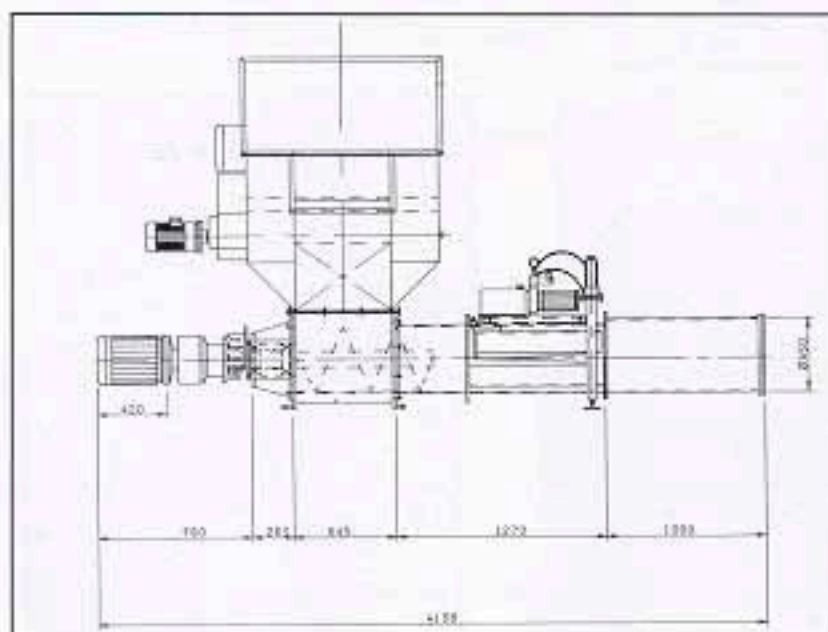

SK 400 SH with hydraulically controlled jaws and Combi Hopper

(Feed Hopper with integrated pre-crusher for Polystyrene).

- ✓ Planetgear 11 kW motor
- ✓ Pre-Crusher 1.1 kW
- ✓ Hydraulic Station 0.55 kW
- ✓ Cabinet for automatic system.
- ✓ Photoelectric cell for automatic start / stop.
- ✓ Weight: 1100 kg.
- ✓ 3 x 380 V or 3 x 220V, other voltages are available.
- ✓ Approx. 22 A at full load.

RUNI is willing to try any of your material!

Producer:

Maskinfabrikken **RUNI** ApS
Industriparken 8
DK-6880 Tarm
DENMARK

Tel. +45 9737 1799
Fax +45 9737 3800

www.runi.dk
E-mail: runi@runi.dk

Distributed by:



PROYECTOS NAVALES
E INDUSTRIALES LIMITADA

Teniente Blason 621
Independencia
Fono: (2) 777 7337
Fax: (2) 732 2362
Email: pronaves@pronaves.cl
SANTIAGO - CHILE

MASKINFABRIKKEN

RUNI ApS

Worm compactor for EPS

Type SK 370 H



The worm compactor compresses EPS fish boxes in the ratio of 50:1

When doing this you obtain about 300 kg/m³



Here you see the machine with the hopper for manual filling of fish boxes. Special solutions are made if needed.

The machine is furnished with hydraulic / electronic controlled jaws, which makes it possible to conserve an almost constant compression pressure.

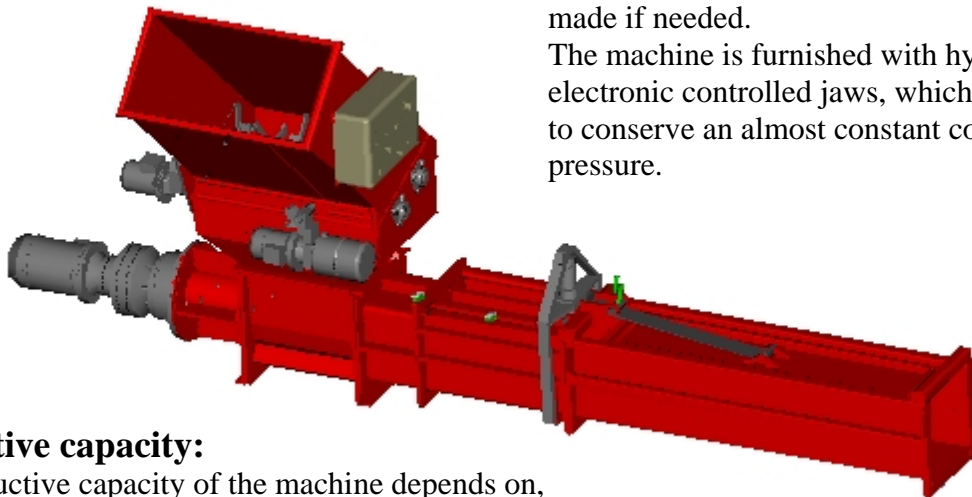

Productive capacity:

The productive capacity of the machine depends on, how dry the EPS is, and what shape it has.

The machine compresses about 200 kg of EPS pr hour (about 300 fish boxes including lids)

Energy consumption:

Main motor: 15 kW.

Hydraulic pump: 0,55 kW.

Pre cruiser: 1,1 kW.

Dimensions:

Length: 5,17 m

Breadth: 1,35 m

Height: 2,20 m

The machine is a patent solution to reduce volume and carrying expenses of the EPS

REPRESENTANTE EN CHILE

PROYECTOS NAVALES E INDUSTRIALES LIMITADA

E MAIL pronaves@pronaves.cl

FONO (2) 7777337

TENIENTE BISSON 821 – INDEPENDENCIA

FAX (2) 7322382

SANTIAGO - CHILE



PRONAVES Ltda.

®